

Front View

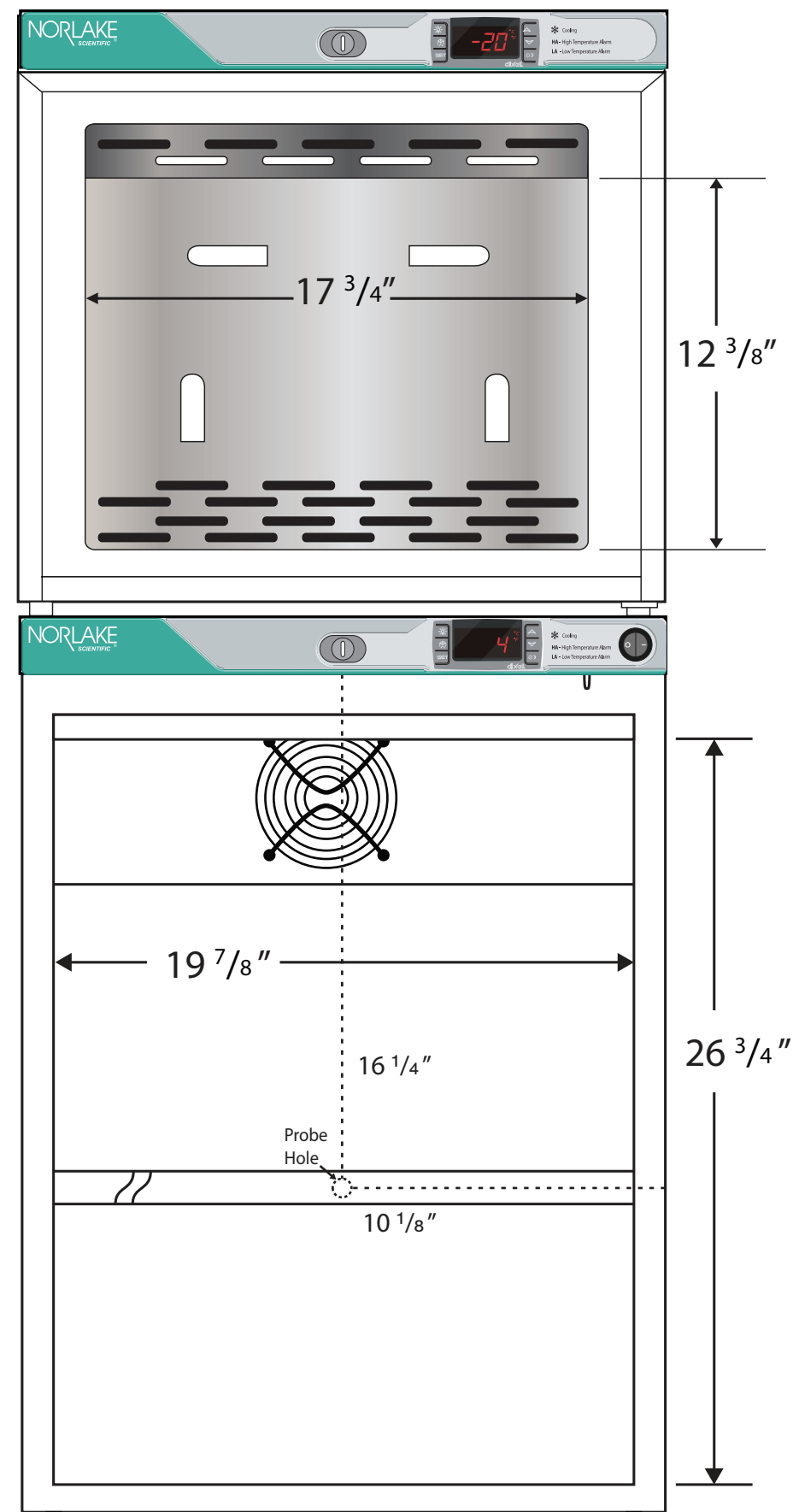

Side View

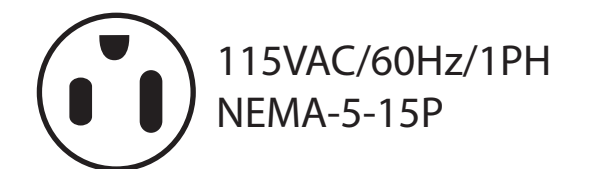
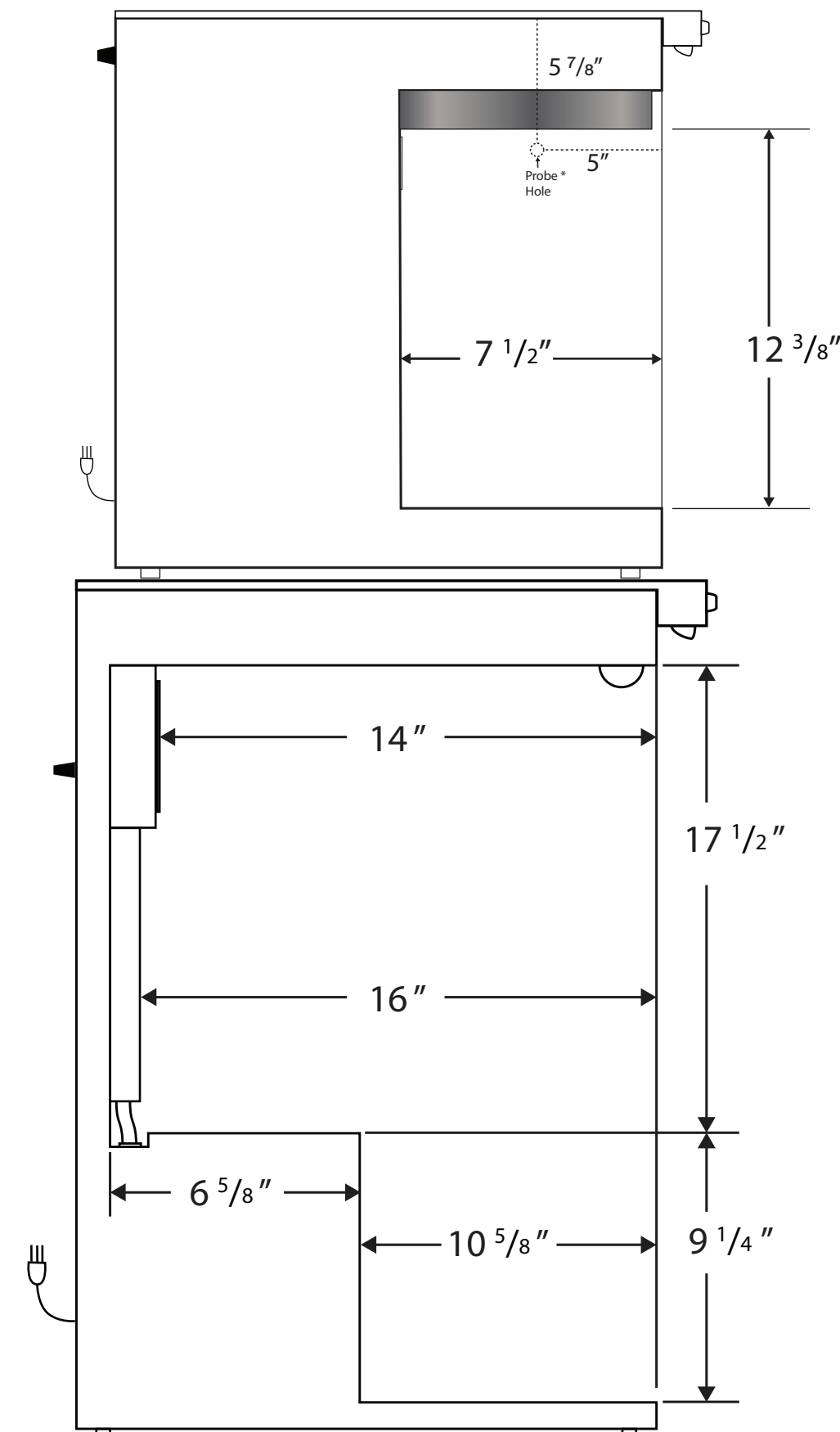

Compartment	Cu. Ft	Defrost	Door	Int Door	Shelves	Interior Dim.			Refrigerant	H.P.	Amps	Weight
						W"	D"	H"				
Freezer	1	Controlled Auto Cycle	1 Solid 1 Glass	0	2 Adj 3 Adj	17 3/4	7 1/2	12 3/8	R600a	1/8	1	135 lbs.
Refrigerator	5.2					19 7/8	16	26 3/4		1/6	1.3	

Note: Interior dimensions are estimates and subject to change without notice